

TITLE

EQUIPMENT/FURNISHINGS - SEAT BELT BRACKET INSPECTION

EFFECTIVITY

MODEL	SERIAL NUMBERS
120	8000 thru 15075
140	8000 thru 15075

REASON

Cessna Aircraft Company wishes to update the seat belt bracket for airplanes in the field to the latest design.

DESCRIPTION

This service bulletin provides parts and instructions to do an inspection of the seat belt bracket and to replace it if necessary.

COMPLIANCE

MANDATORY. This service bulletin must be accomplished at the next 100-hour or 12-month (annual-type) inspection.

APPROVAL

Cessna received FAA approval for the technical data in this publication that changes the airplane type design.

Cessna received EASA approval for the technical data in this publication that changes the airplane type design.

WEIGHT AND BALANCE INFORMATION

Negligible

REFERENCES

Cessna applicable model maintenance manual

ACCOMPLISHMENT INSTRUCTIONS

1. (Refer to Figure 1.) Do the visual inspection of the seat belt bracket to make sure that the latest type of seat belt bracket is installed as follows:
 - A. If there is a step on the seat belt bracket, go to Step 2.
 - B. If there is no step on the seat belt bracket, do as follows:
 - (1) Prepare the airplane for maintenance.
 - (a) Make sure that the airplane is electrically grounded.
 - (b) Make sure that all switches are in the OFF/NORM position.
 - (c) Disconnect electrical power from the airplane.
 - 1 Disconnect external electrical power.
 - 2 Disconnect the airplane battery.
 - (d) Attach maintenance warning tags to the battery and external power receptacle that have **"DO NOT CONNECT ELECTRICAL POWER - MAINTENANCE IN PROGRESS"** written on them.
 - (2) Remove the seat belts from the seat belt bracket.
 - (3) Remove and discard the seat belt bracket. Keep the serviceable attachment hardware.
 - (4) Install the new 0425132 Seat Belt Bracket with the kept attachment hardware.
 - (5) Install the seat belts on the seat belt bracket.
 - (6) Remove the maintenance warning tags and connect the airplane battery.
2. Make an entry in the airplane logbook that states compliance and method of compliance with this service bulletin.

B20517

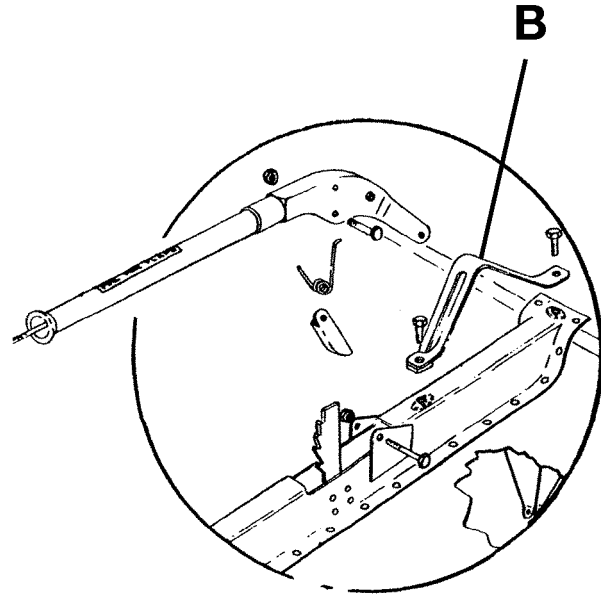
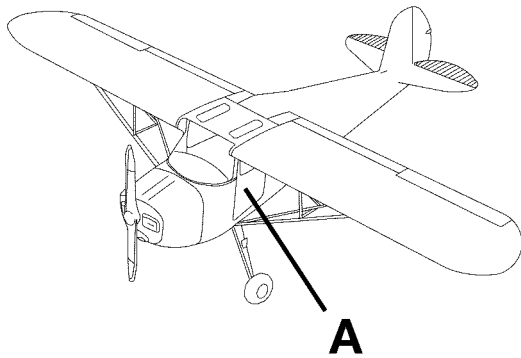

DETAIL A

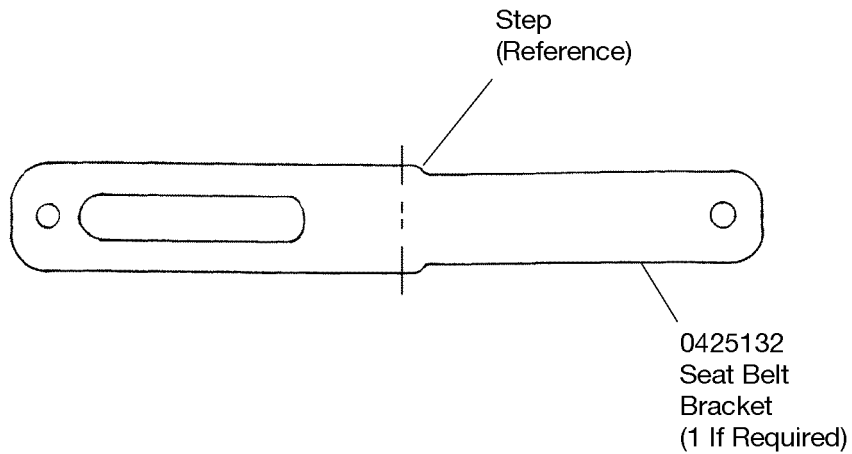

DETAIL B

0410T1005

Figure 1. Seat Belt Bracket Inspection (Sheet 1)

MATERIAL INFORMATION

Order the part below to install this modification.

NEW P/N	QUAN- TITY	KEY WORD	OLD P/N	INSTRUCTIONS/ DISPOSITION
0425132	1	Seat Belt Bracket	Various	Discard

TITLE

EQUIPMENT/FURNISHINGS - SEAT BELT BRACKET INSPECTION

TO:

Cessna 120 and 140 Owners

REASON

Cessna Aircraft Company wishes to update the seat belt bracket for airplanes in the field to the latest design.

DESCRIPTION

This service bulletin provides parts and instructions to do an inspection of the seat belt bracket and to replace it if necessary.

COMPLIANCE

MANDATORY. This service bulletin must be accomplished at the next 100-hour or 12-month (annual-type) inspection.

LABOR HOURS

No additional man-hours are required for the inspection.

If necessary, 0.7 man-hour is required to do the replacement of the seat belt bracket.

WARRANTY

Not applicable.

Please contact a Cessna Authorized Service Facility for detailed information and arrange to have Cessna service bulletin SEB-25-03 accomplished on your airplane.

Access the QR code for the instructional video link that follows or use the URL address:



Select this link:

<http://servicecdn.txtav.com/SEB-25-03/SEB-25-03.html>

NOTE: As a convenience, service documents are now available online to all our customers through a simple, free-of-charge registration process. If you would like to sign up, please visit the "Customer Access" link at www.cessnasupport.com to register.

