

*Fly Smart and Be Safe*

## **An Aircraft Owner's Guide to Operating and Maintaining your Aircraft**



Prepared by:  
***The FAA Safety Team - FAASTeam***

Contact: *timothy.j.sokol@faa.gov*

Revision 2: September 12, 2012

## Introduction

The Aircraft Owner's Guide is a guide to understanding your airworthiness and operational responsibilities as an aircraft owner or operator. Much of this information is a result of years of research into the common problems and lessons learned from General Aviation accidents and incidents. It focuses on certain tasks that have a tendency to be overlooked, taking into account the perspective of both the licensed pilot and maintenance technician. It provides a list of ideas to help prevent you from making these mistakes by learning from the misfortune of others.



*"Learn all you can from the mistakes of others. You won't have time to make them all yourself"*

Alan Sheinwold

## Some Dos and Don'ts;

**Do:** Construct and use a customized and detailed preflight checklist

Cessna 152 Checklist	
Preflight	
	
<b>CABIN</b>	
1. Check Discrepancies and Inspections	
2. Required Papers in Airplane (AROW)	
2. Enter HOBBS Reading on TACH Sheet	
3. Control Wheel Lock . . . . . REMOVE	
4. Ignition Switch . . . . . OFF	
5. Master Switch . . . . . ON	
6. Fuel Gauges . . . . . QUANTITY	
7. Flaps . . . . . 30°	
8. Master Switch . . . . . OFF	
9. Fuel Shutoff Valve . . . . . ON	
<b>2) FUSELAGE AND EMPENNAGE</b>	
1. Fuel Drain . . . . . DRAIN	
2. Fuselage/Empennage . . . . . CHECK CONDITION	
3. Rudder Gust Lock . . . . . REMOVE	
4. Tail Tie-down . . . . . DISCONNECT	
5. Control Surfaces . . . . . CHECK Attachment and Movement	
6. Empennage-Fuselage . . . . . CHECK CONDITION	
<b>3) RIGHT WING TRAILING EDGE</b>	
1. Flap . . . . . CHECK Attachment and Movement	
2. Aileron . . . . . CHECK Attachment, Movement, and Counterweights	
<b>4) RIGHT WING</b>	
1. Wing Tie Down . . . . . DISCONNECT	
2. Undercarriage/Tire . . . . . CHECK Condition, Inflation, and Brakes	
3. Fuel Drain . . . . . DRAIN	
4. Fuel Quantity . . . . . DIP/MEASURE	
5. Fuel Filler Cap . . . . . SECURE (Check Vent)	
6. Wing Surface . . . . . CHECK CONDITION	
7. Windshield . . . . . CLEAN	
<b>5) NOSE</b>	
1. Engine Oil Level . . . . . 4-6 QUARTS	
2. Fuel Sump . . . . . DRAIN	
3. Prop Spinner . . . . . CONDITION	
4. Alternator Belt . . . . . TIGHT	
5. Oil Cooler . . . . . UNOBSTRUCTED	
6. Landing Light . . . . . CLEAN	
7. Air Filter . . . . . UNOBSTRUCTED	
8. Wheel Strut/Tire . . . . . CHECK Condition and Inflation	
9. Static Port . . . . . UNRESTRICTED	
<b>6) LEFT WING</b>	
1. Fuel Quantity . . . . . DIP/MEASURE	
2. Fuel Filler Cap . . . . . SECURE (Check Vent)	
3. Pitot Tube . . . . . UNRESTRICTED/CLEAR	
4. Fuel Tank Vent . . . . . CLEAR	
5. Wing Tie Down . . . . . DISCONNECT	
6. Stall Warning . . . . . OPERATION	
7. Wing Surface . . . . . CHECK CONDITION	
<b>7) LEFT WING TRAILING EDGE</b>	
1. Aileron . . . . . CHECK Attachment, Movement, and Counterweights	
2. Flap . . . . . CHECK Attachment and Movement	
3. Undercarriage/Tire . . . . . CHECK Condition, Inflation, and Brakes	
4. Remove Chalks . . . . . SECURE TOW BAR	

NIGHT PREFLIGHT	
1. Master Switch . . . . . ON	
2. Beacon/Strobes . . . . . TEST	
3. NAV Lights . . . . . TEST	
4. Landing Light . . . . . TEST	
5. Interior Lights . . . . . TEST	
6. Master Switch . . . . . OFF	

Develop a preflight inspection checklist that is custom to your aircraft. Use a manufacturers' checklist as a basis to develop a more enhanced, comprehensive list of items not normally found in a preflight inspection.

## An Enhanced Preflight should consider the following;

### AIRCRAFT RECORDS

- Installed Documents Check. Verify the required documents installed to legally operate (Airworthiness, Registration, Radio License if required, Operating Limitations, Weight and Balance). ARROW.
- Required Inspection and Maintenance Check. Ensure that the aircraft is within the Annual/100hr (if applicable) inspection interval and properly maintained as required by federal regulations 14 CFR Part 91, subpart E. Review the logbook for any open discrepancies. Be aware of any repeating discrepancies. If you are renting an aircraft be aware of any repeat discrepancies and always question any uncertainties about any maintenance or inspection item.
- Airworthiness Directives Check. Review the AD summary status sheet. Make sure that all ADs are current and complied with before taking off.
- Major Repairs and Alterations check. Ensure that any mandatory Instructions for Continued Airworthiness (ICAs) have been complied with.

### AIRCRAFT

- Leak check. Look up, look down and look around. Inspect for any fluid that might be leaking from your aircraft. This includes, oil, hydraulic, fuel, alcohol and water. Look for leaks in the engine area and landing gear. In most cases leaks are not normal and they must be investigated further.
- Alternator, Battery and Wiring Check. Inspect for security and condition of critical wiring.
- Hoses, and lines check. Inspect hoses, clamps and fittings for fatigue and age related wear.
- Fuel check. Validate your fuel quantity by looking inside and sticking the tank. **IMPORTANT:** Secure items on you, being careful not to drop anything into the tank while performing the inspection. Visually inspect your sump area for water or sediment contamination. Make sure that your fuel system contains the proper additives specific to the type of operation. Some additives serve dual purposes to prevent icing and biocides that may contaminate the fuel. Lastly verify that the Fuel cap is properly installed.



- Seat Check.** Make sure your seat can be moved and can be secured into a locked position. Visually inspect tracks for wear and cracks. Potential failure here can be catastrophic. Check you seat belts for proper installation and operation. Do not allow passenger on-board without having proper seat restraints.
- Minimum Required Equipment Check.** Ensure that all necessary equipment necessary to operate safely is installed an operating properly. Make sure emergency equipment is installed.
- Windshield Check.** Make sure your visual acuity is the best it can be by cleaning your windshield if necessary. Once you take-off, it is too late.
- Flight control check.** Validate proper movement and indication. Inspect hinges for security. A piano type hinge will have a retaining pin that can come loose and must always be secured properly. Rotating (Pivot) points will be subject to higher than normal loads. Consequently, fatigue, wear, cracks, corrosion and eventual failure will occur if not inspected and maintained. Load bearing hardware will eventually wear and fail and should be inspected and maintained in-between required inspections.
- Weight and Loaded Center of Gravity check.** Calculate loaded c.g. and compare it to the published operating limitations. An overloaded aircraft or improperly distributed c.g can cause havoc on operating an aircraft in critical situations.

<u>Center of Gravity</u>	(+85.1)	to	(+93.5)	at	1850 lb. or less
	(+87.0)	to	(+93.5)	at	2100 lb.
	(+87.9)	to	(+93.5)	at	2140 lb.
	Straight line variation between points given.				

Empty Weight C. G. Range      None

Maximum Weight                      2140 lb.

No. of Seats                              4    (2 at +85.5, 2 at +118.1)

Maximum Baggage                      125 lb. at (+142.8)

Fuel Capacity                            50 gallons at (+95) (2 wing tanks)  
See NOTE 1 for data on system fuel.

Oil Capacity                              8 quarts at (+32.5) (6 quarts usable)  
See NOTE 1 for data on system oil.

**Don't:** Assume your aircraft was in the same configuration as you left it before. People have a natural tendency to move things. Switches and handles can be moved as well as flight controls and adjustable tabs. Be especially aware if you are not the only operator or are a co-owner, or using a rental aircraft.



**Do:** A thorough inspection of your aircraft after maintenance has been performed

If your aircraft flight controls cables were removed, you must validate that the proper movement (up and down, or side to side) and verify proper indication in the cockpit. The degree of travel must also be validated. Verify the proper entries were made and the problem was fixed.



When you have your aircraft painted you must ensure afterwards, the flight controls operate freely and were rigged properly. Painting is considered "preventative maintenance" yet it is considered "substantial maintenance" for large aircraft." You should have a detailed discussion with your paint technician BEFORE the aircraft is painted. A good painter will remove and rebalance control surfaces and tabs (when applicable) to ensure proper weight and balance. S/he will not paint hardware, cable, rubber, bearings and areas that normally are not painted. A good painter will carefully remove old paint, not to cause damage to the underlying metal by using equipment that can scratch the metal and cause stress points that can eventually lead to problems. Get the details before work is done, so there are no surprises later.

**Do:** Understand your responsibilities for the airworthiness of your airplane. 14CFR Part 91, Subpart E, outlines owner/operator airworthiness responsibilities. The 91.4XX series rules cover the operating rules and maintenance and inspection intervals and what the owner/operator expectations are. You might be surprised to see what your responsibilities really are.

**Do:** Organize all records and periodically conduct a through records review. Make sure that you have all records of Maintenance, preventative maintenance, Major Alterations and Repairs well documented and organized. Permanent records are required to be maintained.



**Do:** Maintain an Updated Equipment List. You cannot inspect, maintain or operate when you don't know what's in your airplane.

**Don't:** Pull or tug on your retractable landing gear without taking safety precautions. Never troubleshoot a gear problem or go under an aircraft with retractable gear without secondary support. If the gear is not extended passed a break-over point in a down and locked position, then it is susceptible to collapse.



**Do:** Subscribe to ADs and SAIBs at the Regulatory and Guidance Library.

Go to the Regulatory Guidance Library and subscribe to the ADs specific to your aircraft. Remember, you are responsible for your aircraft's airworthiness.

An excellent resource is the Regulatory and Guidance Library for public, non-proprietary information about your aircraft. Remember, the owner/ operator is responsible for airworthiness. You should always maintain a copy and read and understand the TYPE Certificate Data Sheet for the airframe, engine and propeller.

## Regulatory and Guidance Library



The FAA's Regulatory & Guidance Library (RGL) contains many aviation regulatory, certification and safety information documents.

Select an information category from the list to the right.

Subscribe to [ADs and SAIBs](#)

For a short and simple path to RGL, enter the following in your web browser's address line: <http://rgl.faa.gov>.

Send RGL questions or comments to the FAA at [9-AWA-AIRRGL@faa.gov](mailto:9-AWA-AIRRGL@faa.gov).

### **Additional Links:**

[Aircraft Certification Homepage](#)

[New RGL Reference Guide](#)

[New RGL FAQs](#)

RGL V15.1. - 08/03/2009

[Advisory Circulars](#)

[-- Draft Advisory Circulars](#)

[Airworthiness Directives](#)

[-- AD NPRMs](#)

[CARs/CAMs/Aero-Bulletins](#)

[Equivalent Levels of Safety](#)

[Exemptions](#)

[Code of Federal Regulations](#)

[-- CFR NPRMs](#)

[-- CFR Final Rules](#)

[Orders/Notices](#)

[Parts Manufacturer Approvals](#)

[Policy](#)

[Regulatory Basis Tool](#)

[Special Airworthiness](#)

[Information Bulletins](#)

[Special Conditions](#)

[Supplemental Type Certificates](#)

[Technical Standard Orders and](#)

[Index](#)

[Type Certificate Data Sheets](#)

[\(Make Model\)](#)

Mandatory Compliance: FAA Approved Manuals, Type Certificate Data Sheets. Airworthiness Directives. Instructions for Continued Airworthiness. Federal Aviation Regulations.

**Do:** Become familiar with your aircrafts common problems. There are many resources found on the internet such as Special Airworthiness Information Bulletins (SAIB) and Aviation Maintenance Alerts which are updated monthly in AC-43-16.



**ADVISORY CIRCULAR**

43-16A

**AVIATION MAINTENANCE ALERTS**

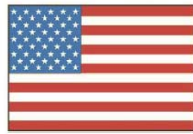

**ALERT  
NUMBER  
405**

**APRIL  
2012**





SAIB: CE-09-15  
Date: March 2, 2009

SUBJ: Landing Gear - Nose Gear Centering Attach Bolt

*This is information only. Recommendations aren't mandatory.*

## Introduction

This Special Airworthiness Information Bulletin (SAIB) alerts you, owners, or operators, of all serial numbers of Piper Aircraft, Inc. (Piper) Models PA-34-200, PA-34-200T and PA-34-220T airplanes of an airworthiness concern and the potential failure of the nose landing gear to extend as a result of the bolt head becoming jammed against the aft tube assembly-nose gear door actuation. This failure is due to a hex-head bolt on the nose gear centering spring rod-end to the nose gear strut, coming in contact with the nose gear door actuation aft tube assembly. This action impedes/prevents the extension of the nose gear assembly.

At this time, this airworthiness concern is not an unsafe condition that would warrant AD action under Title 14 of the Code of Federal Aviation Regulations (14CFR) part 39.

## Background

This SAIB is a result of an incident on a Piper Model PA-34-200 airplane that occurred during an approach to land in which the nose gear failed to extend. Post incident investigation revealed that the hex-head bolt on nose gear centering spring had come in contact with nose gear door actuation tube assembly. This action prevented the nose gear assembly from exiting the wheel well area in normal operations and during emergency procedures.

Piper had a similar problem several years ago which resulted in a publication of Service Bulletin (SB) No. 893 dated October 11, 1988. This SB recommended an inspection of the nose gear assembly to include replacement of the hex-head bolt with a clevis bolt and washers to prevent the nose gear failure. The Piper Model PA-34-220T airplane was certified after SB 893 was published; however, it has the same nose gear assembly. All S/N PA-34-220T aircraft should have the clevis head bolt installed at the factory but they should also be included.

## Recommendations

The purpose of this SAIB is to provide information to reduce the possibility of failure to the nose gear. We recommend that you incorporate Piper Service Bulletin No. 893, dated October 11, 1988, which specifies inspecting the nose gear center spring assembly for proper bolt (**replace the hex-head bolt with a clevis bolt**) along with washer installations and proper alignment to centering bracket.

## For Further Information Contact

Hector Hernandez, Aerospace Engineer, FAA, Central Region, Atlanta Aircraft Certification Office, One Crown Center, 1895 Phoenix Boulevard, Suite 450, Atlanta, GA 30349; phone (770) 703-6069; fax (770) 703-6097; email: [Hector.Hernandez@faa.gov](mailto:Hector.Hernandez@faa.gov)

**Don't:** Ignore Mandatory Service Bulletins, Service Letters and Service Instructions. Although Mandatory Service Bulletins are NOT considered Mandatory by the FAA in most circumstances, they could be an important safety concern. Mandatory Service Bulletins in Part 91 operations can only be enforced if referenced in an FAR, Airworthiness Directive or Type Certificate Data Sheet (excluding notes sect.). Many Mandatory Bulletins can be precursors to ADs and may pose an inherent safety risk if not complied with. Exercise proper risk management when carrying passengers if you do not comply with these bulletins.



The New Piper Aircraft, Inc.  
2926 Piper Drive  
Vero Beach, Florida, U.S.A. 32960

# SERVICE No. 1161 BULLETIN

**PIPER CONSIDERS  
COMPLIANCE MANDATORY**

Date: March 8, 2006 (S)(M)

**SUBJECT:**

**RIB ASSEMBLY INSPECTION & MODIFICATION -  
AFT WING, WS 49.25**

**MODELS AFFECTED:**

PA-28R-180 Arrow  
PA-28R-200 Arrow  
PA-28R-200 Arrow II  
PA-28R-201 Arrow III  
PA-28R-201T Turbo Arrow III  
PA-28RT-201 Arrow IV

**SERIAL NUMBERS AFFECTED:**

28R-30002 through 28R-31270; 28R-7130001 through  
28R-7130013  
28R-35001 through 28R-35820; 28R-7135001 through  
28R-7135229  
28R-7235001 through 28R-7635545  
28R-7737002 through 28R-7837317; 2837001 through  
2837061; 2844001 through 2844127  
28R-7703001 through 28R-7803374; 2803001 through  
2803012  
28R-7918001 through 28R-7918267; 28R-8018001  
through 28R-8218026

**Don't:** Perform a maintenance task that you have not done before or not authorized to perform. Seek assistance even with preventative maintenance items that you have not previously performed or unsure of performing.

**Don't:** Operate your aircraft after it has not been operating for awhile unless you have considered the following:

- Condition of Oil – Oils can oxidize over time and break down. Remember that the function of oil is to lubricate to prevent friction and wear, dissipate heat and prevent corrosion. Oxidation and corrosion is the enemy of oil breakdown. Dark oil does not necessarily indicate dirty oil.
- Condition of Fuel – Fuel can go stale (oxidize) over time.
- Condition of Belts and Hoses and Wires.
- Configuration and Condition of Aircraft – Be aware of animals that might find your aircraft as their new home.

Always perform a proper run-up and leak check.

**Don't:** Switch to Automotive Gasoline or a different Octane Fuel without authorization and performing extensive research. There is both mandatory and advisory guidance available.



**Don't:** Clean rubber hoses or items without using the proper solvent. Certain solvents are not compatible with materials and cause more damage than good. These can cause premature aging and dry rot.





**Don't:** "Hop in and Go" after long term storage or long periods between flying. Fuel will go stale. Seals fail. Materials age even when sitting. Unseen but exposed engine parts will corrode.

**Don't:** Put yourself and others in a hurried situation. Allow enough time to properly plan a trip.

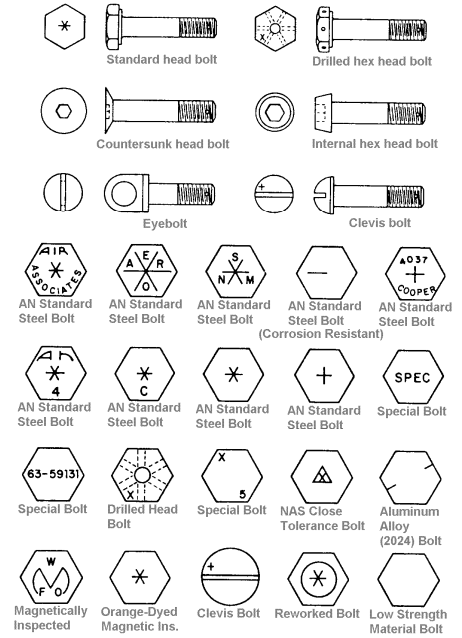
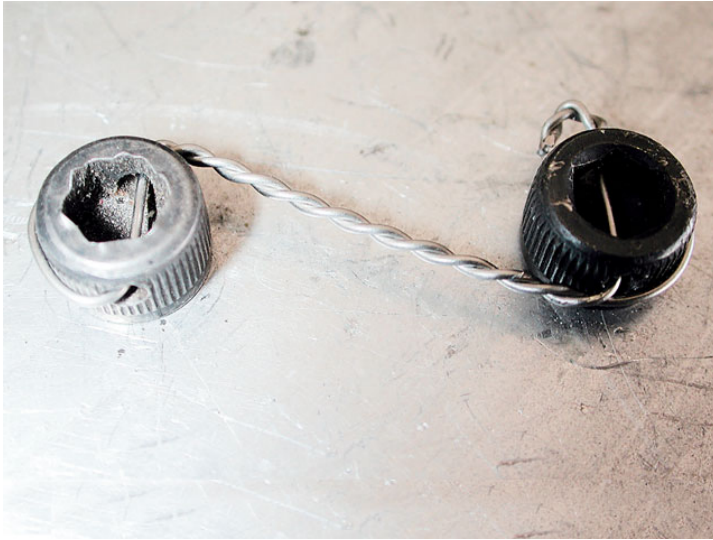

**Do:** Exercise proper techniques and Best Practices found AC 43.13





## ADVISORY CIRCULAR



---

### AC 43.13-1B

# ACCEPTABLE METHODS, TECHNIQUES, AND PRACTICES — AIRCRAFT INSPECTION AND REPAIR

CONSOLIDATED REPRINT  
 Incorporates change 1

September 8, 1998

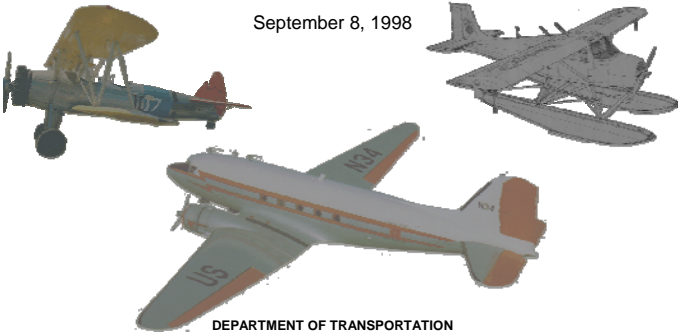

DEPARTMENT OF TRANSPORTATION  
 FEDERAL AVIATION ADMINISTRATION  
 Flight Standard Service  
 Regulatory Support Division, AFS-600

---

For sale by the Superintendent of Documents; U.S. Government Printing Office; Washington, DC 20402

**Do:** Establish and maintain an onboard inspection kit to conduct such as a mirror and flashlight and simple tools.



**Don't:** Ignore placards and warnings. Make sure these are installed, they are regulatory.



**Do:** Mark systems inoperative and/or removed.

**Don't:** Allow welding on your aircraft structure unless the process is either FAA approved or in accordance with an industry recognized standard. Welding can cause stress on alloyed metals and steel that can lead to catastrophic failure if stress relief is improperly performed.

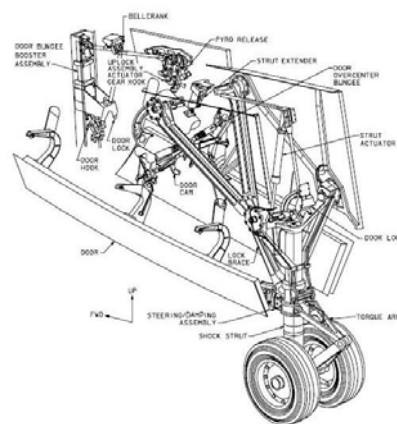

Nose Landing Gear Deployed

# Aircraft Weight and Balance

## ***An often overlooked and misunderstood requirement***

FAR Part 91 operating rules require that a person knows the maximum gross weight before take-off. It is very important for all pilots to understand that operating an aircraft in an overweight condition or out of C.G., can adversely affect the performance and handling characteristics of their aircraft. Although weight and Balance is not considered a top leading offender in most GA accidents, there is a great deal of evidence that weight and balance was a significant contributing factor.



Weight affects not only the normal performance characteristics but also how the aircraft operates under environmental conditions that are influenced by temperature, humidity and barometric pressure. These factors can potentially result in unsafe environmental conditions such as an adverse density altitude and icing conditions. The performance characteristics can be reduced by these conditions during situations where power applications are required to maintain speed and execute critical maneuvering.

Weight and C.G. Balance can have a direct effect on:

*Flight Control Operating Range – Excessive Trim & Range Limitations - Climb Rate Performance- Maneuvering - Airspeed – Attitude Control - Approach and Landing Speed and Control - Engine and Propeller Power Settings – Runway limitations (both takeoff and landing) – Fuel Management and Burn Rate – Braking - Emergency Management - Adverse behavior in Turbulence – Stall Speed - Spin Recovery.*

Aircraft that are manufactured have specific weight and balance limitations engineered for safe operation. Aircraft owners and operators must be aware that many small aircraft cannot operate safely with all seats occupied and baggage compartments full with fuel at maximum capacity. These restrictions are especially critical in aircraft having 4 or more seats. Baggage compartment weight restrictions must be adhered to including floor loading restrictions and even distribution of weight in these compartments. One common fallacy is the use of published weights in substitution of the actual passenger weight. These can easily cause an unbalanced condition especially in tight ranged, multiple seat aircraft. Actual weights used are a best practice in determining the loaded c.g.

Published Weight and Balance operating limitations are normally found on the aircraft's Type Certificate Data Sheet and the Limitations section of the Flight Manual. These limitations have more restrictive envelopes for operation where maneuvering is critical such as aerobatic operations.

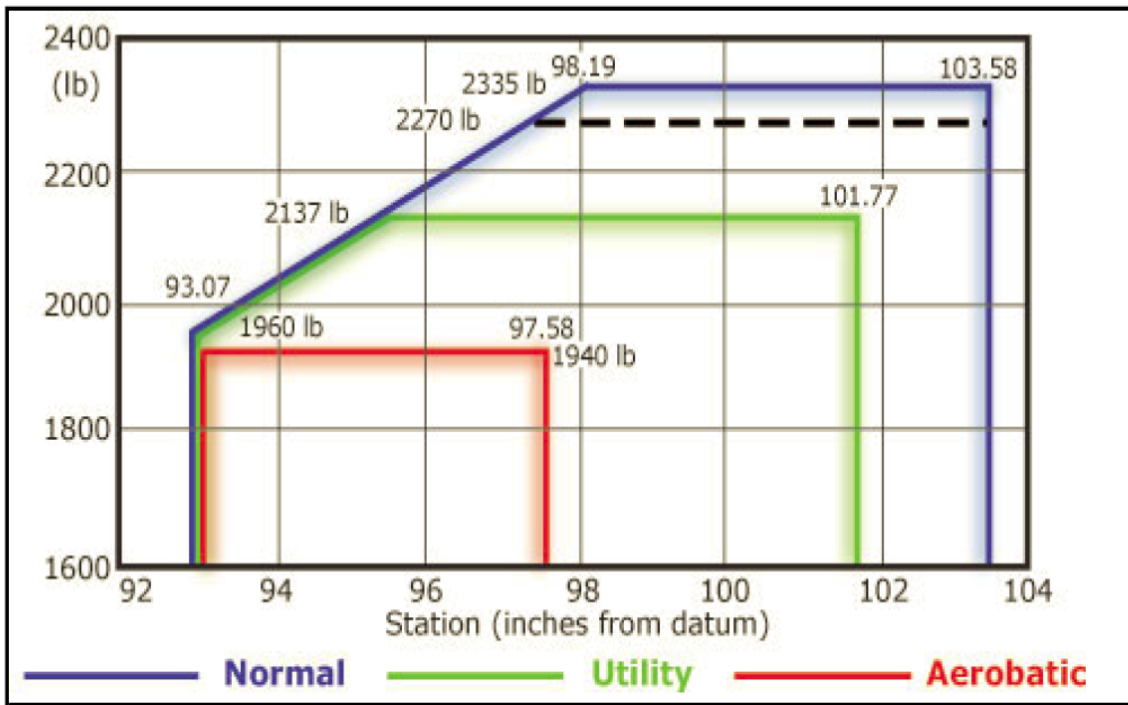

An accurate Empty Weight must be known and calculated Loaded C.G. should be known prior to takeoff. The owner operator must also know the loaded weight compared to the published maximum gross weight.

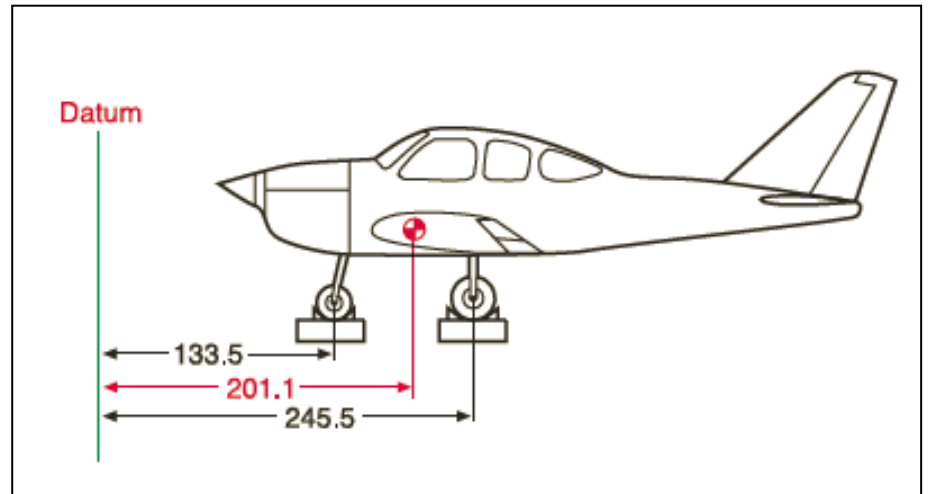
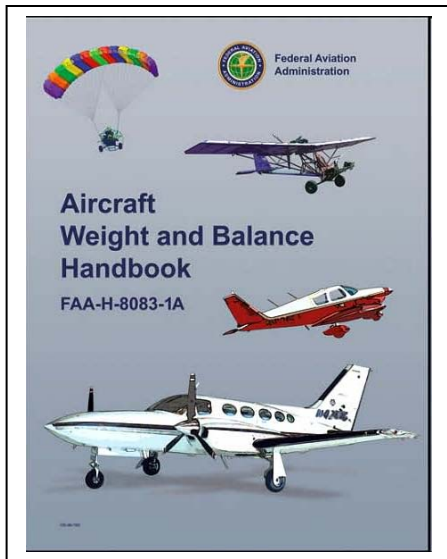

Item	Weight	Arm	Moment
Main wheels	3,540	245.5	869,070
Nose wheel	2,322	133.5	309,987
Total	5,862		1,179,057

An excellent resource for calculated empty weight C.G. is FAA-H-8083-1A. This document is free on the internet.

Item	Weight 2,300 max	Arm	Moment	CG +35.6 to +43.2
Airplane	1,340	37	49,580	
Front Seats	255	35	8,925	
Rear Seats	309	72	22,248	
Fuel	240	48	11,520	
Baggage	50	92	4,600	
	2,194		96,873	44.1

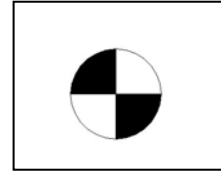

Construct a Table similar to these to determine the loaded Center of Gravity prior to take-off.

Item	Weight (3,100 max.)	Arm (inches)	Moment (lb-in)	CG (in/datum)
Airplane (BEW)	1,874	36.1	67,651.4	
Front seats	300	37	11,100	
Rear seats	175	74	12,950	
Fuel (88 gal usable)	528	46.6	24,604.8	
Baggage A (100 max.)	100	97	9,700	
Baggage B (60 max.)	50	116	5,800	
	3,027		131,806.2	+ 43.54

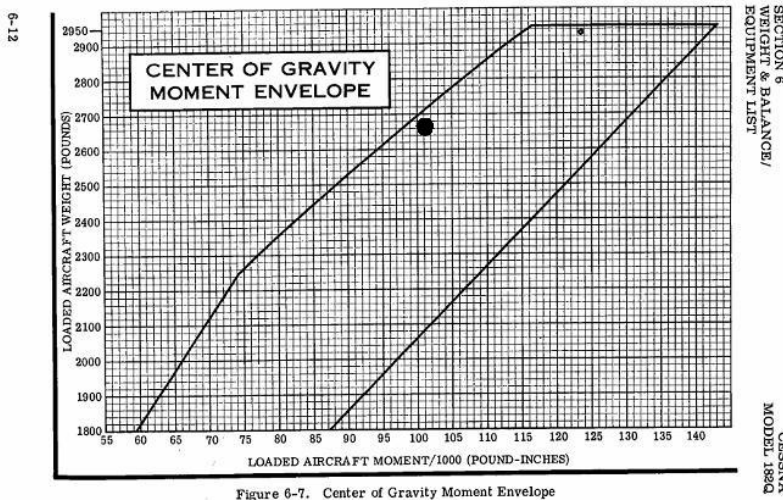

Operate only within the prescribed safe C.G. envelope.

# Owner/Operator Maintenance, Preventative Maintenance, Repairs and Alterations



Course Supplement  
Provided by: The GL FAASTeam  
January 27, 2012  
Rev. Original

# The Pilot...

## Student



## Private



## Commercial



## Sport & Recreational





## WHAT GUIDANCE SHOULD I USE WHEN PERFORMING PREVENTATIVE MAINTENANCE?

FAR 43.13 requires the use of manufacturer's maintenance manuals. Use may AC 43.13. when manuals are no manufacturer's manuals available.



## CAN I DO MY OWN ANNUAL INSPECTION UNDER THE SUPERVISION OF A MECHANIC OR IA?

No. FAR 43.3 does not allow a mechanic to Supervise an Inspection under Part 91. Only an IA can perform an Annual Inspection. (ref. 65.95)

## CAN I DO A 100 HOUR INSPECTION UNDER THE SUPERVISION OF A MECHANIC OR IA?

No. FAR 43.3 does not allow a mechanic to Supervise an Inspection under Part 91. (ref. 65.81)

## CAN I PERFORM MY OWN MAINTENCE ON MY OWN AIRCRAFT?

You are permitted to perform your own maintenance, repairs and alterations as long as they are minor and only under the supervision of a certificated mechanic that has done the work before. (ref. FAR 65.81). A maintenance entry, other than preventative maintenance, must be made by the certificated mechanic indicating his/hers certificate number.

## HOW DO YOU DEFINE "UNDER THE SUPERVISION?"

Personally observes the work that is being done to the extent necessary to ensure that it is being done properly and if the supervisor is readily available, in person, for consultation. (ref. FAR 43.3)

## WHAT ABOUT A REPAIRMAN, CAN THEY SUPERVISE MAINTENANCE?

Yes, however the Repairman must be familiar with the task and be appropriately certificated. Repairman ratings are issued to perform specific maintenance or inspection functions. (ref. 65.103). Repairman certificates are not issued for Airframe and Powerplant ratings.

## HOW DO I KNOW IF MY REPAIR or ALTERATION is MAJOR or MINOR?

A list of Major Repairs, Major Alterations and Preventative Maintenance is found in FAR 43.3 and 43 Appendix A. FAR 1.1 states that if improperly done, might appreciably effect weight, balance, structural strength, performance, powerplant operation, flight characteristics, or other qualities affecting airworthiness or That is not done according to accepted practices or cannot be done by elementary operations.

## HOW COME I CAN'T DO MAJOR REPAIRS AND ALTERATIONS TO MY OWN AIRCRAFT?

Major repairs and alterations require special documentation and reference acceptable or approved data. This documentation must be submitted to the FAA on an FAA Form 337. An unlicensed person is not authorized to sign these forms or perform the work, even when supervised. These operations are not elementary and require special skills and training by licensed professionals.

---

## USEFUL REFERENCES:

The Regulatory Guidance Library Website <http://rgl.faa.gov/> is an excellent resource for:

FARs  
Advisory Circulars, Orders and Notices  
Airworthiness Directives  
Special Airworthiness Information Bulletins  
Type Certificate Data Sheets  
Supplemental Type Certificates  
CAMs and CARs

## Regulatory and Guidance Library



The FAA's Regulatory & Guidance Library (RGL) contains many aviation regulatory, certification and safety information documents.

Select an information category from the list to the right.

Subscribe to [ADs and SAIBs](#)

For a short and simple path to RGL, enter the following in your web browser's address line: <http://rgl.faa.gov>.

Send RGL questions or comments to the FAA at [9-AWA-AIRRGL@faa.gov](mailto:9-AWA-AIRRGL@faa.gov).

### Additional Links:

[Aircraft Certification Homepage](#)  
[New RGL Reference Guide](#)  
[New RGL FAQs](#)

RGL V15.1. - 08/03/2009

[Advisory Circulars](#)  
[-- Draft Advisory Circulars](#)  
[Airworthiness Directives](#)  
[-- AD NPRMs](#)  
[CARs/CAMs/Aero-Bulletins](#)  
[Equivalent Levels of Safety](#)  
[Exemptions](#)  
[Code of Federal Regulations](#)  
[-- CFR NPRMs](#)  
[-- CFR Final Rules](#)  
[Orders/Notices](#)  
[Parts Manufacturer Approvals](#)  
[Policy](#)  
[Regulatory Basis Tool](#)  
[Special Airworthiness](#)  
[Information Bulletins](#)  
[Special Conditions](#)  
[Supplemental Type Certificates](#)  
[Technical Standard Orders and](#)  
[Index](#)  
[Type Certificate Data Sheets](#)  
[\(Make Model\)](#)

## Code of Federal Regulations

14 CFR PART 43

### ▼ Appendix A

Part 43 MAINTENANCE, PREVENTIVE MAINTENANCE, REBUILDING, AND ALTERATION
---

#### (a) Major alterations--

(1) ***Airframe major alterations.*** Alterations of the following parts and alterations of the following types, when not listed in the aircraft specifications issued by the FAA, are airframe major alterations:

- (i) Wings.
- (ii) Tail surfaces.
- (iii) Fuselage.
- (iv) Engine mounts.
- (v) Control system.
- (vi) Landing gear.
- (vii) Hull or floats.
- (viii) Elements of an airframe including spars, ribs, fittings, shock absorbers, bracing, cowling, fairings, and balance weights.
- (ix) Hydraulic and electrical actuating system of components.
- (x) Rotor blades.
- (xi) Changes to the empty weight or empty balance which result in an increase in the maximum certificated weight or center of gravity limits of the aircraft.
- (xii) Changes to the basic design of the fuel, oil, cooling, heating, cabin pressurization, electrical, hydraulic, de-icing, or exhaust systems.
- (xiii) Changes to the wing or to fixed or movable control surfaces which affect flutter and vibration characteristics.

(2) ***Powerplant major alterations.*** The following alterations of a powerplant when not listed in the engine specifications issued by the FAA, are powerplant major alterations.

- (i) Conversion of an aircraft engine from one approved model to another, involving any changes in compression ratio, propeller reduction gear, impeller gear ratios or the substitution of major engine parts which requires extensive rework and testing of the engine.
- (ii) Changes to the engine by replacing aircraft engine structural parts with parts not supplied by the original manufacturer or parts not specifically approved by the Administrator.
- (iii) Installation of an accessory which is not approved for the engine.
- (iv) Removal of accessories that are listed as required equipment on the aircraft or engine specification.
- (v) Installation of structural parts other than the type of parts approved for the installation.
- (vi) Conversions of any sort for the purpose of using fuel of a rating or grade other than that listed in the engine specifications.

(3) ***Propeller major alterations.*** The following alterations of a propeller when not authorized in the propeller specifications issued by the FAA are propeller major alterations:

- (i) Changes in blade design.
- (ii) Changes in hub design.
- (iii) Changes in the governor or control design.
- (iv) Installation of a propeller governor or feathering system.
- (v) Installation of propeller de-icing system.
- (vi) Installation of parts not approved for the propeller.

(4) ***Appliance major alterations.*** Alterations of the basic design not made in accordance with recommendations of the

appliance manufacturer or in accordance with an FAA Airworthiness Directive are appliance major alterations. In addition, changes in the basic design of radio communication and navigation equipment approved under type certification or a Technical Standard Order that have an effect on frequency stability, noise level, sensitivity, selectivity, distortion, spurious radiation, AVC characteristics, or ability to meet environmental test conditions and other changes that have an effect on the performance of the equipment are also major alterations.

## **(b) Major repairs--**

(1) ***Airframe major repairs.*** Repairs to the following parts of an airframe and repairs of the following types, involving the strengthening, reinforcing, splicing, and manufacturing of primary structural members or their replacement, when replacement is by fabrication such as riveting or welding, are airframe major repairs.

(i) Box beams.

(ii) Monocoque or semimonocoque wings or control surfaces.

(iii) Wing stringers or chord members.

(iv) Spars.

(v) Spar flanges.

(vi) Members of truss-type beams.

(vii) Thin sheet webs of beams.

(viii) Keel and chine members of boat hulls or floats.

(ix) Corrugated sheet compression members which act as flange material of wings or tail surfaces.

(x) Wing main ribs and compression members.

(xi) Wing or tail surface brace struts.

(xii) Engine mounts.

(xiii) Fuselage longerons.

(xiv) Members of the side truss, horizontal truss, or bulkheads.

(xv) Main seat support braces and brackets.

(xvi) Landing gear brace struts.

(xvii) Axles.

(xviii) Wheels.

(xix) Skis, and ski pedestals.

(xx) Parts of the control system such as control columns, pedals, shafts, brackets, or horns.

(xxi) Repairs involving the substitution of material.

(xxii) The repair of damaged areas in metal or plywood stressed covering exceeding six inches in any direction.

(xxiii) The repair of portions of skin sheets by making additional seams.

(xxiv) The splicing of skin sheets.

(xxv) The repair of three or more adjacent wing or control surface ribs or the leading edge of wings and control surfaces, between such adjacent ribs.

(xxvi) Repair of fabric covering involving an area greater than that required to repair two adjacent ribs.

(xxvii) Replacement of fabric on fabric covered parts such as wings, fuselages, stabilizers, and control surfaces.

(xxviii) Repairing, including rebottoming, of removable or integral fuel tanks and oil tanks.

(2) ***Powerplant major repairs.*** Repairs of the following parts of an engine and repairs of the following types, are powerplant major repairs:

(i) Separation or disassembly of a crankcase or crankshaft of a reciprocating engine equipped with an integral supercharger.

(ii) Separation or disassembly of a crankcase or crankshaft of a reciprocating engine equipped with other than spur-type propeller reduction gearing.

(iii) Special repairs to structural engine parts by welding, plating, metalizing, or other methods.

(3) ***Propeller major repairs.*** Repairs of the following types to a propeller are propeller major repairs:

(i) Any repairs to, or straightening of steel blades.

- (ii) Repairing or machining of steel hubs.
- (iii) Shortening of blades.
- (iv) Retipping of wood propellers.
- (v) Replacement of outer laminations on fixed pitch wood propellers.
- (vi) Repairing elongated bolt holes in the hub of fixed pitch wood propellers.
- (vii) Inlay work on wood blades.
- (viii) Repairs to composition blades.
- (ix) Replacement of tip fabric.
- (x) Replacement of plastic covering.
- (xi) Repair of propeller governors.
- (xii) Overhaul of controllable pitch propellers.
- (xiii) Repairs to deep dents, cuts, scars, nicks, etc., and straightening of aluminum blades.
- (xiv) The repair or replacement of internal elements of blades.
- (4) *Appliance major repairs.* Repairs of the following types to appliances are appliance major repairs:
  - (i) Calibration and repair of instruments.
  - (ii) Calibration of radio equipment.
  - (iii) Rewinding the field coil of an electrical accessory.
  - (iv) Complete disassembly of complex hydraulic power valves.
  - (v) Overhaul of pressure type carburetors, and pressure type fuel, oil and hydraulic pumps.

## **(c) Preventive maintenance.**

Preventive maintenance is limited to the following work, provided it does not involve complex assembly operations:

- (1) Removal, installation, and repair of landing gear tires.
- (2) Replacing elastic shock absorber cords on landing gear.
- (3) Servicing landing gear shock struts by adding oil, air, or both.
- (4) Servicing landing gear wheel bearings, such as cleaning and greasing.
- (5) Replacing defective safety wiring or cotter keys.
- (6) Lubrication not requiring disassembly other than removal of nonstructural items such as cover plates, cowlings, and fairings.
- (7) Making simple fabric patches not requiring rib stitching or the removal of structural parts or control surfaces. In the case of balloons, the making of small fabric repairs to envelopes (as defined in, and in accordance with, the balloon manufacturers' instructions) not requiring load tape repair or replacement.
- (8) Replenishing hydraulic fluid in the hydraulic reservoir.
- (9) Refinishing decorative coating of fuselage, balloon baskets, wings tail group surfaces (excluding balanced control surfaces), fairings, cowlings, landing gear, cabin, or cockpit interior when removal or disassembly of any primary structure or operating system is not required.
- (10) Applying preservative or protective material to components where no disassembly of any primary structure or operating system is involved and where such coating is not prohibited or is not contrary to good practices.
- (11) Repairing upholstery and decorative furnishings of the cabin, cockpit, or balloon basket interior when the repairing does not require disassembly of any primary structure or operating system or interfere with an operating system or affect the primary structure of the aircraft.
- (12) Making small simple repairs to fairings, nonstructural cover plates, cowlings, and small patches and reinforcements not changing the contour so as to interfere with proper air flow.
- (13) Replacing side windows where that work does not interfere with the structure or any operating system such as controls, electrical equipment, etc.
- (14) Replacing safety belts.
- (15) Replacing seats or seat parts with replacement parts approved for the aircraft, not involving disassembly of any primary structure or operating system.
- (16) Trouble shooting and repairing broken circuits in landing light wiring circuits.

- (17) Replacing bulbs, reflectors, and lenses of position and landing lights.
- (18) Replacing wheels and skis where no weight and balance computation is involved.
- (19) Replacing any cowling not requiring removal of the propeller or disconnection of flight controls.
- (20) Replacing or cleaning spark plugs and setting of spark plug gap clearance.
- (21) Replacing any hose connection except hydraulic connections.
- (22) Replacing prefabricated fuel lines.
- (23) Cleaning or replacing fuel and oil strainers or filter elements.
- (24) Replacing and servicing batteries.
- (25) Cleaning of balloon burner pilot and main nozzles in accordance with the balloon manufacturer's instructions.
- (26) Replacement or adjustment of nonstructural standard fasteners incidental to operations.
- (27) The interchange of balloon baskets and burners on envelopes when the basket or burner is designated as interchangeable in the balloon type certificate data and the baskets and burners are specifically designed for quick removal and installation.
- (28) The installations of anti-misfueling devices to reduce the diameter of fuel tank filler openings provided the specific device has been made a part of the aircraft type certificate data by the aircraft manufacturer, the aircraft manufacturer has provided FAA-approved instructions for installation of the specific device, and installation does not involve the disassembly of the existing tank filler opening.
- (29) Removing, checking, and replacing magnetic chip detectors.
- (30) The inspection and maintenance tasks prescribed and specifically identified as preventive maintenance in a primary category aircraft type certificate or supplemental type certificate holder's approved special inspection and preventive maintenance program when accomplished on a primary category aircraft provided:
  - (i) They are performed by the holder of at least a private pilot certificate issued under part 61 who is the registered owner (including co-owners) of the affected aircraft and who holds a certificate of competency for the affected aircraft (1) issued by a school approved under Sec. 147.21(e) of this chapter; (2) issued by the holder of the production certificate for that primary category aircraft that has a special training program approved under Sec. 21.24 of this subchapter; or (3) issued by another entity that has a course approved by the Administrator; and
  - (ii) The inspections and maintenance tasks are performed in accordance with instructions contained by the special inspection and preventive maintenance program approved as part of the aircraft's type design or supplemental type design.
- (31) Removing and replacing self-contained, front instrument panel-mounted navigation and communication devices that employ tray-mounted connectors that connect the unit when the unit is installed into the instrument panel, (excluding automatic flight control systems, transponders, and microwave frequency distance measuring equipment (DME)). The approved unit must be designed to be readily and repeatedly removed and replaced, and pertinent instructions must be provided. Prior to the unit's intended use, and operational check must be performed in accordance with the applicable sections of part 91 of this chapter.
- (32) Updating self-contained, front instrument panel-mounted Air Traffic Control (ATC) navigational software data bases (excluding those of automatic flight control systems, transponders, and microwave frequency distance measuring equipment (DME)) provided no disassembly of the unit is required and pertinent instructions are provided. Prior to the unit's intended use, an operational check must be performed in accordance with applicable sections of part 91 of this chapter.

Amdt. 43-36, Eff. 5/31/96

**Note: Any comments and inquiries regarding this document should be directed to:  
timothy.j.sokol@faa.gov**